

General Guidelines for Machining AMPCO® and AMPCOLOY® Materials

The machining recommendations for AMPCO® and AMPCOLOY® alloys are derived from extensive testing conducted at AMPCO METAL facilities, corroborated by feedback from numerous customers. While these materials are generally easier to machine than tool steel, particular attention is required for certain grades—namely AMPCO® 21, AMPCO® 22, AMPCO® 25, and AMPCO® 26. These alloys exhibit lower elongation and ductility compared to tool steels of similar hardness, making them more susceptible to fractures if not handled correctly.

Cutting speeds for machining AMPCO® and AMPCOLOY® materials vary significantly based on several factors:

- The type of cutting tools used
- Machine-tool stiffness and stability
- Cooling and lubrication practices
- Overall machine condition

Specific machining speeds for these alloys are detailed in the accompanying table. It is important to note that the rigidity of the machine-tool, efficient heat extraction, and the specific configuration of the cutting tools are crucial, especially when machining the harder AMPCO® grades. Additionally, expect a reduced lifespan of cutting tools when working with these harder grades.

For optimal results, all harder AMPCO® grades (starting from AMPCO® 21 and above) should be machined starting from the edge of the material. Alternatively, edges can be generously chamfered at a 45° angle to prevent edge breakage.

Machining Tools

When machining AMPCO® and AMPCOLOY® alloys, it is essential to set the clearance angle at 6°. Cooling plays a critical role, especially for the harder grades such as M4, 21, 22, 25, and 26. We recommend using water-mixable lubricating coolants, with an emulsion typically containing 5 to 10% cooling lubricant. For components requiring high precision, it is advisable to pre-machine the parts and then allow a 48-hour interval before performing the final machining. In cases demanding very tight tolerances or for thin-walled components, consider a stress-relieving heat treatment either before or, preferably, after pre-machining. For guidance on appropriate temperatures and holding times, please consult your local AMPCO® office.

Sawing

For sawing, softer AMPCO® alloys up to AMPCO® 18 can be effectively cut using bimetal saw blades. However, harder grades such as AMPCO® 21 through AMPCO® 26, and M4 require hard metal saw blades for optimal performance. The tooth count for saw blades should vary between 2 ½ and 3 teeth per inch, depending on the section size of the material being cut.

Manufacturer Recommendation

For hard metal saw blades, we recommend products from WIKUS-Sägenfabrik, Wilhelm H. Kullmann GmbH & Co. KG. More details can be found on their website at www.wikus.de.

Company WIKUS	Company MORSE	AMADA
FUTURA VA 545 (2/3 Carbide Tip)	M Factor GP (2/3 Carbide Tip)	M 71 (Bimetal)
FUTURA VA 545 (3/4 Carbide Tip)	M Factor GP (3/4 Carbide Tip)	DCGW 11T304-2 in P110

Turning

Tool Positioning

When setting up the cutting tool for turning operations, it should be aligned at the center of the part or up to 0.4 mm below the center line.

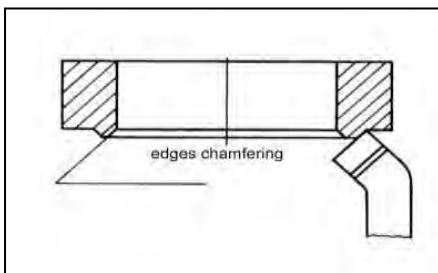

Tool Material and Applications











- **Roughing and Finishing:** For both roughing and finishing operations, we recommend using hard metal cutting tools with K10 / K20 grade tips.
- **Fine Machining:** For achieving a very good surface condition (N3), particularly in applications requiring precise hole-shaft fits, diamond tooling (Polycrystalline Diamond or PKD) is advisable.

Special Considerations for Turning Rings

To prevent edge breakage when turning rings, especially in the harder AMPCO® grades (from AMPCO® 21 and above), it is crucial to machine from the outside to the inside of the material. Alternatively, you can machine a generous 45-degree chamfer on the edge where the cutting tool will finish its operation. This preparation helps in reducing stress and avoiding edge chipping as the tool exits the material.

Parameters for TURNING of AMPCO® & AMPCOLOY®

Alloys	Operation	TURNING		
		Cutting Speed	Feed	Depth
		Vc (m/min)	f (mm/rev)	Depth of Cut (mm)
AMPCO® 18	Roughing	150-200	0.1-0.2	up to 2
	Finishing	180-250	0.05-0.1	0.1 to 0.2
AMPCO® 21, 22	Roughing	120-180	0.1-0.2	up to 1.5
	Finishing	150-200	0.05-0.1	0.1 to 0.2
AMPCO® 25	Roughing	90-150	0.1-0.15	up to 1
	Finishing	120-175	0.05-0.08	0.05 to 0.15
AMPCO® M4	Roughing	150-200	0.1-0.2	up to 2
	Finishing	180-250	0.05-0.1	0.1 to 0.2
AMPCOLOY® 83	Roughing	120-180	0.1-0.2	up to 2
	Finishing	150-200	0.05-0.1	0.1 to 0.15
AMPCOLOY® 88	Roughing	150-225	0.1-0.2	up to 2
	Finishing	170-250	0.05-0.1	0.1 to 0.2
AMPCOLOY® 940,972	Roughing	150-225	0.1-0.2	up to 2
	Finishing	170-250	0.05-0.1	0.1 to 0.2
AMPCOLOY® 944	Roughing	160-240	0.1-0.2	up to 2
	Finishing	180-250	0.05-0.1	0.1 to 0.2
Finish with PCD	Finishing	200-300	0.03-0.08	0.1 to 0.2

Company SECO		Company MITSUBISHI		Company BRISLOY (PCD Tools)		Company ARNO (Parting off tools)	
	CNMG 120408-MF1 in CP500		VCMT 110304-FM in VP15TF		CCGT 060204-1 in P110		21202-AM in AM350
	DCMT 11T304-MF2 in CP500		DCMT 11T304L-F in MD220		DCGW 11T304-2 in P110		SA24-2002N-S1 in AM5040
	DNMU 110404-MF1 in CP500						
	DNMG 150604-MF1 in CP500						
	VBMT 110208-F1 in CP500						

Specific Tool Recommendations for Turning

Seco Tools

- CNMG 120408-MF1 in CP500
- DCMT 11T304-F2 in CP200
- VBMT 160404-F1 in CP500

Sumitomo Tools

- DCGT 11T304 N-SC in ACZ 310
- CNMG 120408 N-EX in EH 510Z
- VBMT 160408 N-SK in EH10Z

WNT Tools (www.wnt.de)

- DCGT 11T302 - AI in CWK15
- CCGT 120404 FN - AI in CWK15

Important Recommendations:

- For alloys AMPCO[®] 21 and above, it is advisable to turn from the edge towards the inside of the part to prevent edge breakage.
- The use of cooling lubricants is highly recommended to enhance the machining process and prolong tool life.

Milling









Tool Recommendations

For milling AMPCO[®] and AMPCOLOY[®] materials, hard metal tools of type K10 – K20 are most effective. These are particularly suitable for machining curves and cavities.

Milling Technique

Shaft Milling Tools, Corner Milling Tools, and Two Lips Milling Tools: When using these tools with hard metal tips, it is essential to machine from the outside towards the inside of the part. Alternatively, chamfer the edges of the part at a 45° angle before beginning the milling operation. This approach helps to prevent edge breakage and ensures smoother operation.

Alloys	Operation	MILLING		
		Cutting Speed	Feed	Depth
		Vc (m/min)	f (mm/rev)	Depth of Cut (mm)
AMPCO® 18	Roughing	110-160	0.1-0.4	up to 4
	Finishing	90-115	0.05-0.1	0.1 to 0.5
AMPCO® 21, 22	Roughing	90-120	0.1-0.2	up to 2.5
	Finishing	75-110	0.05-0.1	0.1 to 0.5
AMPCO® 25	Roughing	90-110	0.1-0.15	up to 1.5
	Finishing	70-90	0.05-0.08	0.1 to 0.5
AMPCO® M4	Roughing	100-150	0.1-0.4	up to 4
	Finishing	90-115	0.05-0.1	0.1 to 0.5
AMPCOLOY® 83	Roughing	80-125	0.1-0.2	up to 2
	Finishing	70-110	0.05-0.1	0.1 to 0.5
AMPCOLOY® 88	Roughing	110-160	0.1-0.4	up to 4
	Finishing	90-115	0.05-0.1	0.1 to 0.5
AMPCOLOY® 940,972	Roughing	100-130	0.1-0.2	up to 2
	Finishing	90-110	0.05-0.1	0.1 to 0.5
AMPCOLOY® 944	Roughing	160-240	0.1-0.2	up to 2
	Finishing	180-250	0.05-0.1	0.1 to 0.2
Finish with PCD	Finishing	300-400	0.03-0.08	0.1 to 0.2

Company SECO		Company CERATIZIT		Company DIXI (Slitting cutter disc)		Company Vardex (Thread Milling)	
	XNEX 080608TR- M13 in F40M		OFHT 040305FN- F10 in CTWN215		Art. 624 - PF.2433.4 91.1		2UI DC60TM in VTX
	XOEX 10T308R-M06 in F40M						
	LOEX 080408TR- M08 in F40M						
	RDHT 10T3M0T-M05 in F40M						
	XOMX 120408TR- ME08 in F40M						

Face Milling

Tool Recommendations

Ingersoll

- PNCU 0805 GNTRJ in IN1030

Widia

- SEKR 1203 AFN-MS THR

Hoffmann Group (www.hoffmann-group.com)

- MPHX 11 in K10/20

Cylindrical Milling

Ingersoll

- Multi cutter SDMT 080305 N in IN1030
- SDCT 080305 FN-P in IN1030

Gühring (www.guehring.de)

- Nr. 3310
- Nr. 3126
- Nr. 3286

Important Recommendations for Milling

1. **Direction of Milling:** For alloys from AMPCO[®] 21 upwards, always mill from the outside of the part towards the inside to ensure stability and minimize the risk of edge breakage.
2. **Tool Type:** Utilize hard metal milling tools with positive cutting angles for better performance and tool life.
3. **Cooling and Lubrication:** The use of cooling lubricant is recommended to improve machining processes and extend the durability of milling tools.
4. **Specifics for High Hardness Alloys (AMPCO[®] 21, 22, 25, 26):** Before face milling operations, remove the edge material first. This preparatory step can help avoid undue stress on the tool and part, ensuring a smoother operation and finish. Detailed procedures can be seen in the [instructional video provided](#).



Scan to watch video

Drilling, Sinking, and Reaming

Tool Selection

For AMPCO® grades 18 to 26, it is crucial to use drills equipped with hard metal plates or fully constructed from hard metal to handle the machining demands of these materials effectively.

Chip Management

Due to the nature of AMPCO® alloys not producing flowing chips, meticulous attention to chip removal is essential. This is particularly important when drilling deep holes; regularly withdrawing the drill to clear chips is recommended to prevent clogging and overheating.

Drilling Techniques

- **Through Holes:** For grades AMPCO® 21 to 26, to avoid part breakage around the exit end of the hole, either place a steel plate underneath the workpiece or perform the drilling from both sides.
- **Cooling:** Effective cooling of the drill is vital when working with both AMPCO® and AMPCOLOY® alloys to ensure tool longevity and optimal performance. Ensuring a very good cooling flow during drilling operations helps in reducing tool wear and preventing thermal damage to the part.

Alloys	Operation	DRILLING, REAMING		
		Cutting Speed	Feed	Depth
		Vc (m/min)	f (mm/rev)	Depth of Cut (mm)
AMPCO® 18	Drilling	90-120	0.15 - 0.2	5 x Ø
	Reaming			
AMPCO® 21, 22	Drilling	80-90	0.1 - 0.15	4 x Ø
	Reaming			
AMPCO® 25	Drilling	70-80	0.1 - 0.12	3 x Ø
	Reaming			
AMPCO® M4	Drilling	80-90	0.1 - 0.15	4 x Ø
	Reaming			
AMPCOLOY® 83	Drilling	55-65	0.1 - 0.12	1 x Ø
	Reaming			3 x Ø
AMPCOLOY® 88	Drilling	80-90	0.1 - 0.15	1 x Ø
	Reaming			3 x Ø
AMPCOLOY® 940,972	Drilling	85-100	0.15 - 0.2	1 x Ø
	Reaming			3 x Ø
AMPCOLOY® 944	Drilling	90-100	0.15 - 0.2	1 x Ø
	Reaming			3 x Ø

Manufacturer recommendation:

Company KOMET/CERATIZIT		Company MITSUBISHI		Company LOCAL Manufacturer for Carbide Drill with IC coolant	
	SOGX 09T308-01 in BK8425		SOMX 084005-UM in mc1020		Carbide grade - CERATIZIT K10, K20, K44 with coating HARD CUT PLUS

Manufacturer recommendation:

Gühring (www.guehring.de)

- For AMPCO® alloys: RT 100 U with article numbers 2471, 1243, 730, 732, and 305.
- For AMPCOLOY® alloys: RT 100 F with article numbers 1660, 1662, and 620.

Important Recommendations

- **Through Holes:** For AMPCO® grades 21, 22, 25, and 26, drilling from both sides is advised to prevent breakage. Use a support plate as shown on the right hand side image to avoid edge damage at the drill exit.
- **Chip Removal:** Effective chip removal is crucial. Regular clearing of chips prevents clogging and reduces tool wear.
- **Cooling:** Utilize cooling lubricants to maintain optimal tool temperature and performance.
- **Peck Drilling:** If chips are too fine, causing potential jamming of reaming tools, implement a pecking cycle to minimize the risk of tool breakage.
- **Reaming Tools:** Use hard metal plates reaming tools with unequal division for enhanced cutting efficiency.
- **Inner Cooling:** Employ drilling tools with internal cooling capabilities and adhere to the manufacturer’s recommended cutting data.

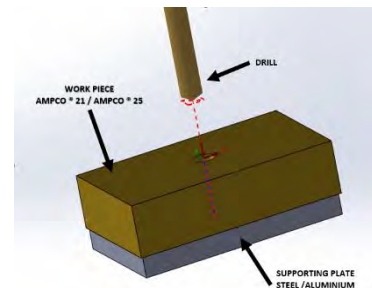



Machining of Threads

For machining threads in medium to hard grades of AMPCO® (grades 18 to 26), the following are recommended:

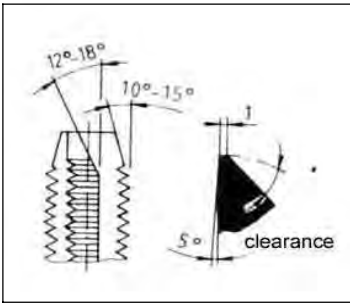
- **Tool Type:** Use thread cutting tools that are relief ground for greater precision and efficiency.
- **Material:** Hard metal thread cutting tools are preferred over High-Speed Steel (HSS) tools as they allow for higher cutting speeds and offer longer tool life.



Alloys	Operation	TAPPING/THREADING		
		Cutting Speed	Feed	Depth
		Vc (m/min)	f (mm/rev)	Depth of Cut (mm)
AMPCO® 18	Tapping	1 x Ø	Equal to Pitch	3 x Ø
AMPCO® 21, 22	Tapping	(1 x Ø)-1	Equal to Pitch	2 x Ø
AMPCO® 25	Tapping	(1 x Ø)-2	Equal to Pitch	1 x Ø
AMPCOLOY® 83	Tapping	1 x Ø	Equal to Pitch	0.5 x Ø
AMPCOLOY® 88	Tapping	1 x Ø	Equal to Pitch	0.5 x Ø
AMPCOLOY® 940,972	Tapping	1 x Ø	Equal to Pitch	0.5 x Ø
AMPCOLOY® 944	Tapping	1 x Ø	Equal to Pitch	0.5 x Ø

Company Guhring		Company OSG	
	969 - 8.000 DIN371		V-XPM-HT
	Art. nr. 969, 2506, 809 and 821		

Drilling Recommendations

Manufacturer: Fa. Gühring (www.guehring.de)

- For AMPCO® alloys: RT 100 U with article numbers 2471, 1243, 730, 732, and 305.
- For AMPCOLOY® alloys: RT 100 F with article numbers 1660, 1662, and 620.
- Additional tools: Article numbers 969, 2506, 809, and 821.

Important Drilling Guidelines

- For AMPCO® grades 25 and 26, the diameter for pre-drilling before tapping should be 0.15 - 0.25mm larger than the standard specified diameter.
- For through-holes, ensure the hole is chamfered on both sides before tapping to prevent edge breakage.

Honing

Honing of AMPCO[®] alloys achieves a geometric precision between 0.0005 and 0.015 mm and surface roughness between 0.5 μm and 1.5 μm , varying by part size and type. For parts with diameters:

- 25 to 130 mm: Allow an undersize of 0.01 to 0.038 mm for honing.
- Over 130 mm up to 280 mm: Allow an undersize of 0.038 mm to 0.063 mm.

Lapping

AMPCO[®] alloys excel in lapping, reaching a precision of 0.1 μm to 2 μm . The preferred lapping powder is corundum.

Grinding and Polishing

AMPCO[®] alloys can achieve excellent surface quality through fine machining. Typical grinding speeds are:

- Deburring: 30 to 45 m/s.
- Flat or round grinding: 24 to 25 m/s. Silicon carbide grinding wheels are recommended, with optimal speeds of 5000 to 6000 RPM for wheels, and 25 to 150 RPM for the part during round grinding. Grinding should be performed wet. Polishing follows similar procedures to steel, beginning with fine machining and progressing to high gloss polishing with a felt wheel and polishing paste.

EDM'ing

AMPCO[®] alloys are readily machinable by Electrical Discharge Machining (EDM) with settings and material removal rates comparable to those used for conventional tool steels in tool making and mold making.

Wire EDM'ing

- **General Process:** Wire EDM'ing of AMPCO[®] and AMPCOLOY[®] alloys is straightforward, although longer machining times are typically necessary.
- **Tooling:** Common brass wires, typically with a diameter of 0.2 mm, are used.

Sink Erosion

- **Focus on AMPCOLOY[®] 940 and 944:** Due to their high thermal and electrical conductivity, these alloys offer advantages in plastic injection molds by allowing faster cooling and shorter cycle times. However, this same property can extend machining times and increase electrode wear during EDM'ing.

Machine Settings and Electrode Material

Machine Settings

Current Intensity

- **Roughing:** High current intensities are essential for rapid material removal during roughing stages.
- **Fine Surface Machining:** Lower current intensities are required to achieve finer surface finishes.
- **Electrode Size Influence:** Larger electrode surfaces necessitate higher currents, while smaller surfaces can operate with less intensity.
- **Material Conductivity:** The excellent electrical conductivity of AMPCOLOY® 940 and AMPCOLOY® 944 typically allows for higher current intensities compared to steel, enhancing the EDM process efficiency.

Polarity

- **Standard Setting:** In modern EDM machines, the standard polarity setting is positive (+) for the electrode and negative (-) for the part being machined.
- **Reversed Polarity:** Depending on the specific EDM machine and the materials involved, especially when using graphite electrodes, it may be necessary to reverse the polarity — negative (-) for the electrode and positive (+) for the part.

On-Time Settings

- **Electrode Material Dependency:** The duration of on-time periods varies with the type of electrode material used. Copper-tungsten and premium graphite electrodes typically allow for longer on-times.
- **Copper Electrodes:** When using copper electrodes, it's crucial to shorten the on-time periods to mitigate high wear rates, ensuring prolonged electrode life and consistent machining quality.

Electrode Material

Copper-Tungsten Electrodes

- **Primary Choice:** Copper-tungsten is the preferred electrode material for sink erosion of AMPCOLOY® 940 and 944 due to its robust material removal rates and durability.
- **Considerations:** While highly effective, copper-tungsten electrodes may be challenging to procure and machine. However, the higher costs are often justified by increased efficiency, particularly with simple geometries like round or square shapes.

Premium-Graphite and Copper-Graphite Electrodes

- **Usage:** These are less favored due to their "dirty" machining characteristics, which can lead to surface contamination.

- **Advantages:** Despite their drawbacks, these electrodes are suitable for EDM'ing AMPCOLOY® 940 and 944, offering a lower wear rate than pure copper electrodes.

Electrolytic Copper Electrodes

- **Common Choice:** Electrolytic copper is widely used for sink erosion due to its availability and cost-effectiveness.
- **Challenges:** It shares similar electrical conductivity properties with AMPCOLOY® 940 and 944, leading to faster wear during EDM'ing.
- **Optimal Use:** Adjusting the EDM machine settings, such as employing short on-time impulses, can minimize wear. Efficient surface flushing during EDM'ing is also crucial to extend the electrode's lifespan.

AMPCOLOY® 972 Electrodes

- **Customer Preference:** AMPCOLOY® 972 is favored for its ease of machining and compatibility with advanced "copper-copper technology" or "copper-AMPCOLOY® technology" settings on EDM machines, resulting in superior outcomes.
- **Availability:** AMPCOLOY® 972 electrodes are readily available from our stock in a variety of dimensions, allowing for immediate application.