

APPLICATION DATA OF AMPCO ALLOYS

APPLICATION: Slipper shoes for rolling mill universal joint couplings.

DESCRIPTION: The stand of a rolling mill contains a screw down nut to raise and lower the rolls which determine the thickness of metals being processed. Misalignment due to the up and down movement between the driving motors and the wobbler or universal end of the roll must be compensated. This is done at the spindle stand by employing universal joint couplings on both ends of the spindle, which connect the rolls to the motor drive. Several types of couplings are used, but the most favored is shown in the sketch. This employs slipper shoes or bearing segments between the spindle pod and spindle end of the rolls. These slippers provide a bearing surface at all areas where contact is made with other metals.

MATERIAL: AMPCO® 18-136 is a heat-treated aluminum bronze especially developed for use in mill slippers. The following are its physical properties:

Tensile strength, psi.....	90,000
Yield strength, psi(.5% in 2").....	38,000
elongation, % in 2".....	18
Brinell(3000kg).....	165
Rockwell by conversion.....	85B
elastic limit in compression, psi.....	41,000
shear strength, psi.....	56,000
izod, foot pounds.....	25
fatigue, psi.....	33,000

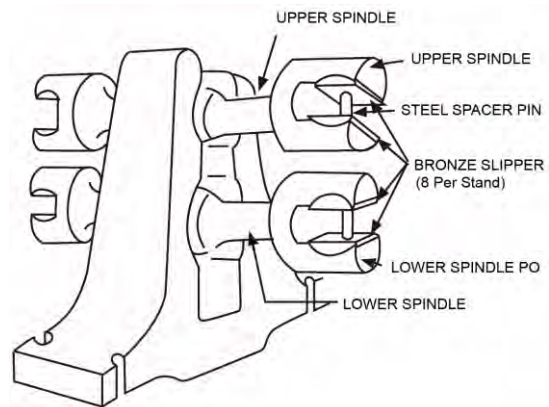

METHOD OF MANUFACTURE: Sand cast and finish machined or cast-to-size to 1/32" tolerance

ADVANTAGES: Slippers of AMPCO® 18-136 alloy give:

- a. Resistance to excessive fatigue...safeguard against breaking when subjected to flexing.
- b. Wear resistance...for extended operation with minimum wear on the spindle.
- c. Resists heavy loads...which occur at increased operating angles.
- d. Impact resistance...sufficient to take a reasonable degree of slap, without breaking after excessive clearance develops.
- e. Low coefficient of friction...affords protection if lubrication fails.

GENERAL: Some slippers are made in the tin-lead bronzes. These alloys, however, do not possess the strength and hardness required for this service. Most mills using these alloys have a captive bronze foundry, which does not pour aluminum bronze; particularly, a special heat-treated alloy as recommended here. Some slippers are cast in high tensile brass (manganese bronze). This alloy has a comparatively poor coefficient of friction and fatigue life, so tends to crack in service. Some mills specify ASTM-B-148-9C aluminum bronze, which is a better alloy than the tin-lead or manganese bronzes. None of them, however, have the long wearing quality of the special heat-treated AMPCO® 18-136 alloy.