

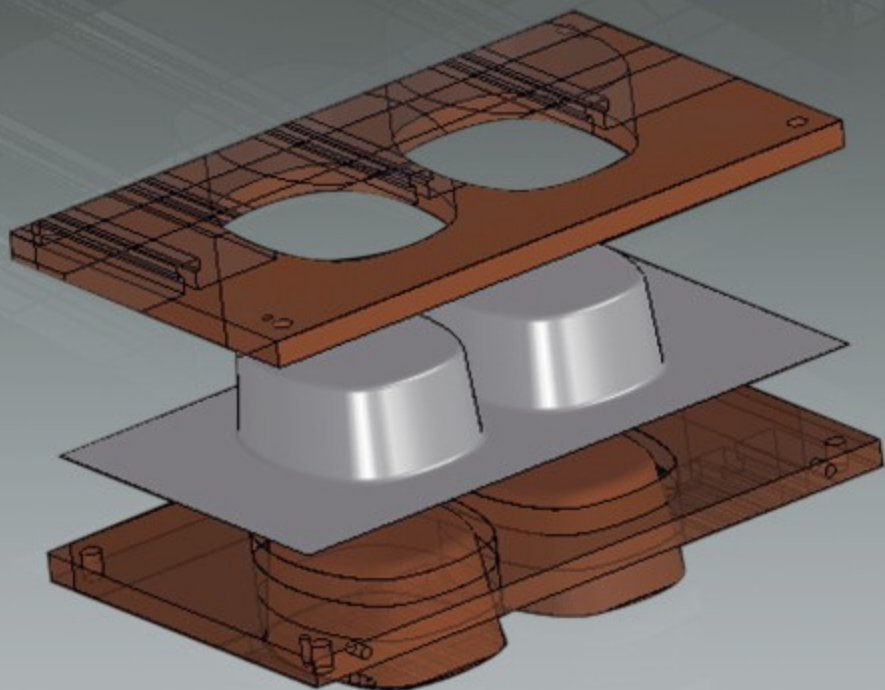

# DEEP DRAWING



AMPCO METAL **EXCELLENCE IN ENGINEERED ALLOYS**



# ALUMINIUM BRONZES

AMPCO Reference	ASTM	Nominal Chemical Composition (Remainder Cu)							Mechanical & Physical Properties								Usage Guideline			Recommended applications
		Sn	Zn	Pb	Al	Fe	Ni	Mn	D	Rm	R <sub>p0.2</sub>	A <sub>5</sub> %	HBW 10/3000	Therm. conductivity	Linear expansion Coefficient	Coefficient Friction Unlubricated	Need for Lubrication	Average speed m/s	Average load Mpa	
									Kg/dm <sup>3</sup>	MPa	MPa			W/m K						
AMPCO <sup>®</sup> BRONZE	AMPCO <sup>®</sup> 8	0.25			6.5	2.5			7.95	552	283	40	153	54	16	0.17	Moderate	1.5	85	Used whenever good resistance to corrosion, abrasion and cavitation pitting is essential. Ideally suited in chemical and marine industries. In boiling material it is used also for bushings, bearings and wear strips.
									0.287	80	41			31	8.89			4.9	12.3	
	AMPCO <sup>®</sup> 18				10.5	3.5			7.45	724	365	14	192	63	16	0.18	Moderate	1.5	100	Food approval material. Alloy well suited for use as gears, worm wheels, bushings and bearings. Standard for all applications requiring sliding wear and fatigue resistance. Used in the steel industry as screw down nuts, slippers, breaker blocks.
									0.269	105	53			36.2	8.89			4.9	14.5	
	AMPCO <sup>®</sup> 18.23				10.5	3.5			7.45	758	386	16	207	59	16	0.18	Moderate	1.5	100	This heat treated alloy gives a maximum resistance to distortion. It gives successful performance under heavy load and impact conditions.
									0.269	110	56			33.9	8.89			4.9	14.5	
	AMPCO <sup>®</sup> 21				13.1	4.4		2	7.21	758	420	1	286	46	16	0.21	Moderate	0.7	115	Used for wear strips replacing hardened steel, and for some cams when no impact is involved. The largest use is as die rings inserts, forming rolls in bending, forming and drawing operation. Widely used as support blades for centerless grinding.
									0.261	110	61			26.4	8.89			2.3	16.7	
	AMPCO <sup>®</sup> 22				14.1	4.7		2	7.06	724	427	0.5	332	42	16	0.25	Moderate	0.6	120	Duplex structure with approximately 50% of phase gamma 2 and 50% of phase beta. Excellent compression and wear resistance. Used in forming and drawing where it's essential that tolerance be maintained.
									0.255	105	62			24.1	8.89			2	17.4	
AMPCO <sup>®</sup> 25								6.93	R <sub>mc</sub> 1580	R <sub>pc</sub> 0.1 710	0.2	364	33	16	0.30	Moderate	0.5	125	This is a patented alloy. The extreme hardness, compressive strength and good friction properties makes it ideal for forming material, especially when stainless steel or titanium is the material being processed. Used as forming rolls bending and wiper dies. Essential in the deep drawing process.	
								0.250	229	103			19	8.89			1.6	18.1		
AMPCO <sup>®</sup> 26								6.93	R <sub>mc</sub> 1601	R <sub>pc</sub> 0.1 720	0	420	33	16	0.32	Moderate	0.4	130	This patented alloy shows an extreme hardness which gives exceptional results. Due to this extreme hardness this material needs special attention in handling and machining. Use for stainless steel drawing dies, forming rolls under great stress and extreme pressures.	
								0.250	232	104			19	8.89			1.3	18.9		
AMPCO <sup>®</sup> 45	AMS 4640 AMS 4880			10	2.5	5	1.5	7.53	814	517	15	228	46	16.2	0.23	High	1.5	90	High strength alloy with applications involving abrasive wear, friction, deformation and chemical erosion, aircraft bushings, pump and marine shafts and wear rings, valve spindles and seats, machine tools parts. Spark resistance properties make it suitable for safety tools in explosive environments.	
								0.272	118	75			26.4	9.00			4.9	13.1		
AMPCO <sup>®</sup> M4	AMS 4590 AMS 4881			10.5	4.8	5	1.5	7.45	1000	793	8	260/300	42	16	0.23	High	1.0	330	Food approval material. Developed for aircraft specifications. Alloy for gear and retractable landing assemblies, engine spacer bearings. It is growing in use where higher mechanical properties at elevated temperatures together with corrosion resistance properties are required. Typical applications in tube bending process. (Mandrels wiper dies).	
								0.269	145	115			24.1	8.89			3.3	47.9		



# AMPCO® Aluminium Bronze Production Process

Casting :



Transformation :



Forging process on a frame in AMPCO® 25.



AMPCO® 25 tube.  
Rings are used to shape wheel rims.

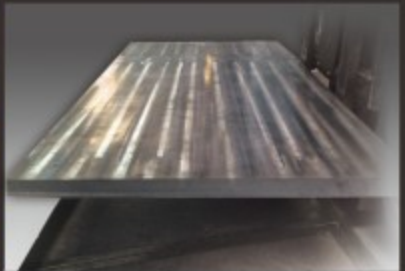

Plate in AMPCO® 25.

In addition to offering our alloys , AMPCO can assist you providing finished parts, according to your specifications and drawings.



Water- cutting process for deep drawing tools. AMPCO® 25 plate. Dimensions : 1800x1100x50 mm.



Pre machined plate in AMPCO® 25.

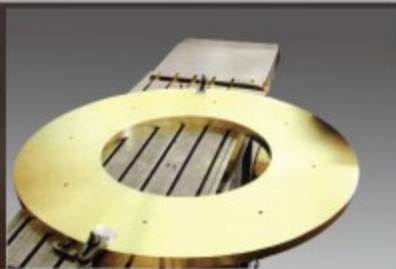

Deep drawing ring in AMPCO® 25. Up to 1700 mm.

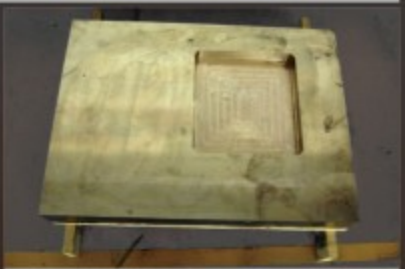

AMPCO® 25 rectangle die with blind hole. 225 kg.

## AMPCO® Aluminium Bronze

These superior alloys are used when tearing, scratching and galling cannot be tolerated. AMPCO® 25 and 26 for long production and severe requirements. AMPCO® 21 and 22 for short runs and moderate service.



Pre-machined round die for washer / drier.

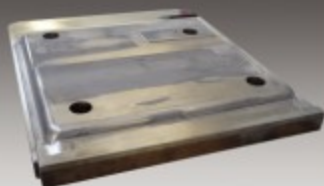

Punch for washing machine.

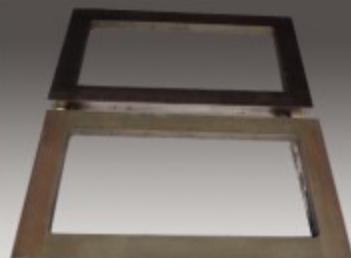

AMPCO® 25 frames.

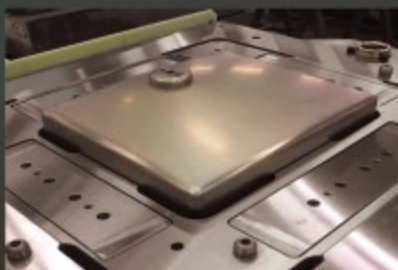

Punch for sink in AMPCO® 26.

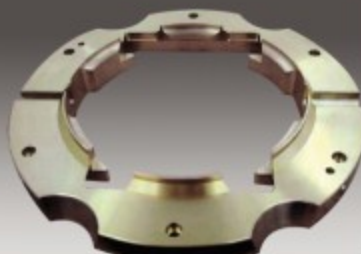

Die for a washer / drier.  
AMPCO® 25 forged. Diameter  
between 500 to 800 mm.

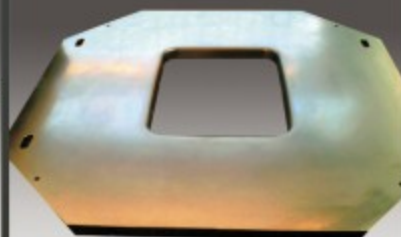

AMPCO® 26 dies  
for sink production.



Blank holder for stainless steel  
sinks production.

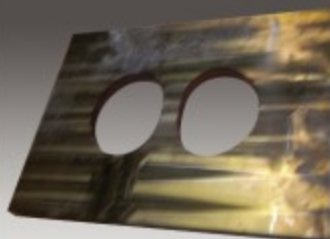

Die in AMPCO® 25.  
Plate is 1200x800x50 mm.



Die and blank holder in  
AMPCO® 25 for pans production.

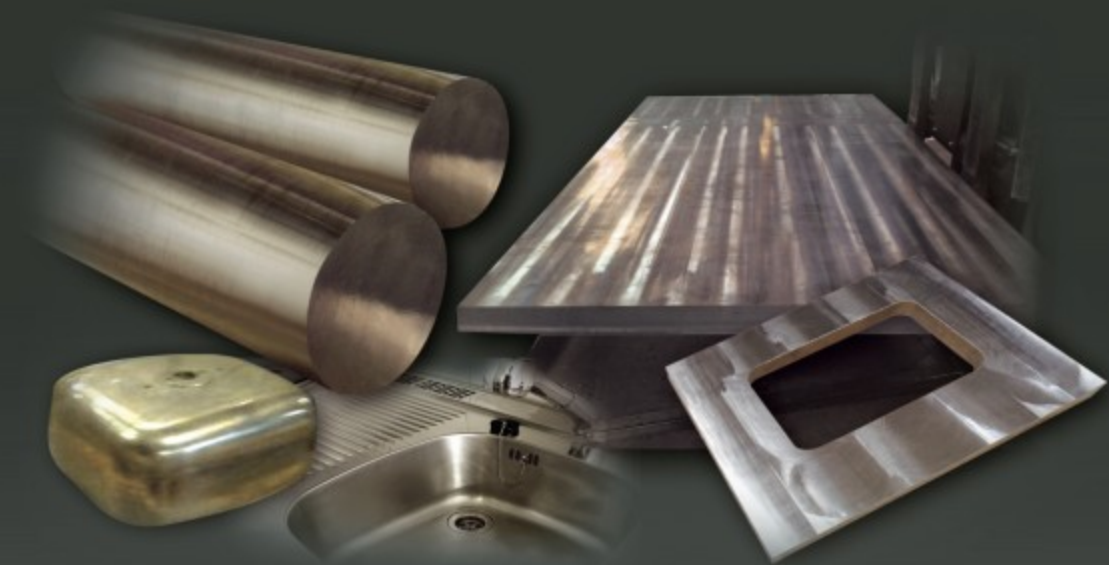

#### EUROPE (Headquarter)

##### AMPCO METAL S.A.

Route de Chésalles 48  
P.O. Box 45, 1723 Marly  
SWITZERLAND  
TOLL FREE PHONE: 800 8080 5050  
Tel.: + 41 26 439 93 00  
Fax: + 41 26 439 93 01  
info@ampcometal.com

#### CHINA

##### AMPCO METAL (Foshan) Co.Ltd.

Warehouse 3-A, No 9 Xinyue Road  
Jinqiao Industrial city, Wusha  
Daliang Town, Shunde, Foshan  
Guangdong Province, P.R. China  
P.C. 528333  
TOLL FREE PHONE: 4008 899 028  
Tel.: + 86 (0) 757 2232 6571  
Fax: + 86 (0) 757 2232 6570  
infochina@ampcometal.com

#### INDIA

##### AMPCO METAL INDIA PVT LTD

Gat no. 357/73, Plot no.12&13,  
Waghjainagar road,  
Kharabwadi Chakan,  
Pune 410501,  
MAHARASHTRA INDIA  
Tel.: + 91 2135 610810  
Fax: + 91 2135 610811  
infoindia@ampcometal.com

#### USA

##### AMPCO METAL Inc.

1117 East Algonquin Road  
Arlington Heights 60005, Illinois  
USA  
TOLL FREE PHONE: 800 844 6008  
Tel.: + 1 847 437 6000  
Fax: + 1 847 437 6008  
infousa@ampcometal.com