



EXCELLENCE IN ENGINEERED ALLOYS

TUBE BENDING TOOLING

PROVIDING END-TO-END
SOLUTIONS FOR
ROTARY DRAW
BENDING

www.ampcometal.com



For over a century, AMPCO METAL has been partnering with diverse industries to craft critical solutions. We've mastered the materials for friction & wear resistance and excelled in heat and electrical conductivity applications. AMPCO METAL's solutions are truly revolutionary for the metal forming industry.

Tube bending is a metal forming process used to permanently form tubes by bending them. Tubes are an integral part of many industries, be it as exhaust systems in the automotive industry, as handrails in the furniture industry, as lines for service in the marine industry, fuel lines in the aerospace industry, bulk carrier in the process industry or fluid transfer in the HVC industry: bent tubes are significantly more useful than in their straight form.

We supply tools for:

- Automotive
- Aerospace
- Railways
- Furniture
- Food packaging
- Boiler industry
- Ship building
- Hygienic fittings
- Process equipment
- Pump industry
- Hydraulic fittings
- Tube bending machine manufacturers

AMPCO METAL offers end-to-end solutions (from design to customer-end validation) of entire Rotary draw tube bending tool set. This includes durable items like bend die, clamp die, pressure die, collet in special steel material & consumables like ball mandrel & wiper die in AMPCO® Bronzes. The selection of tool material depends upon the material & bend configuration of the tube.

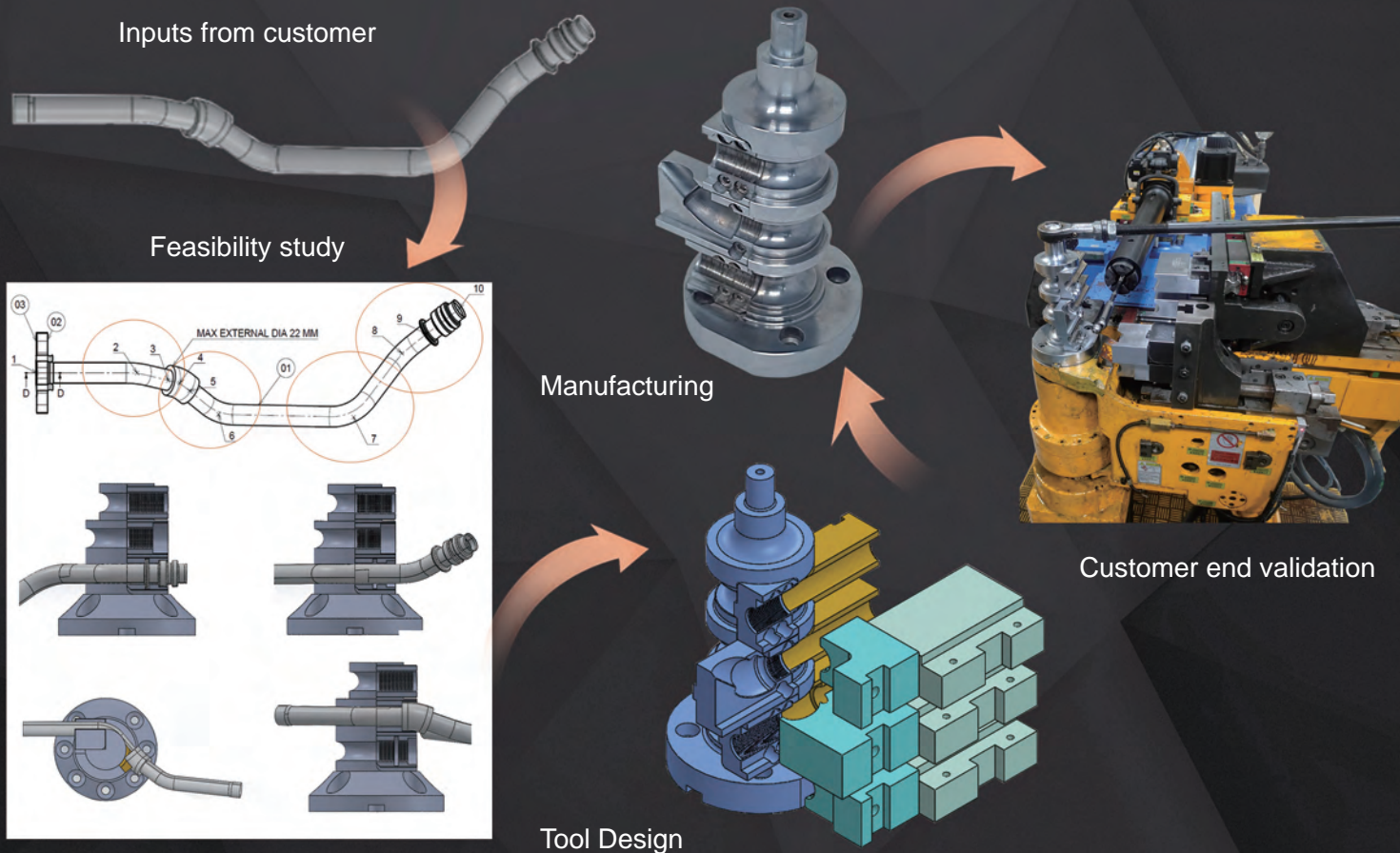

FACILITIES

Our worldwide distribution network enables us to fulfill finished machined parts requirements for various applications in the United States, Europe, Asia, and India while meeting time-sensitive requirements from our customers.

Leverage our expertise on tube bending tooling applications, we provide :

- Inhouse design center for the tube bend tools
- A One-Stop-Shop solution for machining, heat treatment, coating & post processing the tools
- Production of parts to your specification and blueprints
- Inhouse production of all the consumables e.g. ball mandrels, mandrel links, wiper dies etc.
- Shortest lead-time

We have the knowledge, expertise, and a wide range of machining equipment for your projects, including 5-axis CNC machinery, turn-mill center, wire cutting machine & conventional machine for high-precision parts and automatization robots for bigger lots.



INSPECTION & QUALITY CONTROL

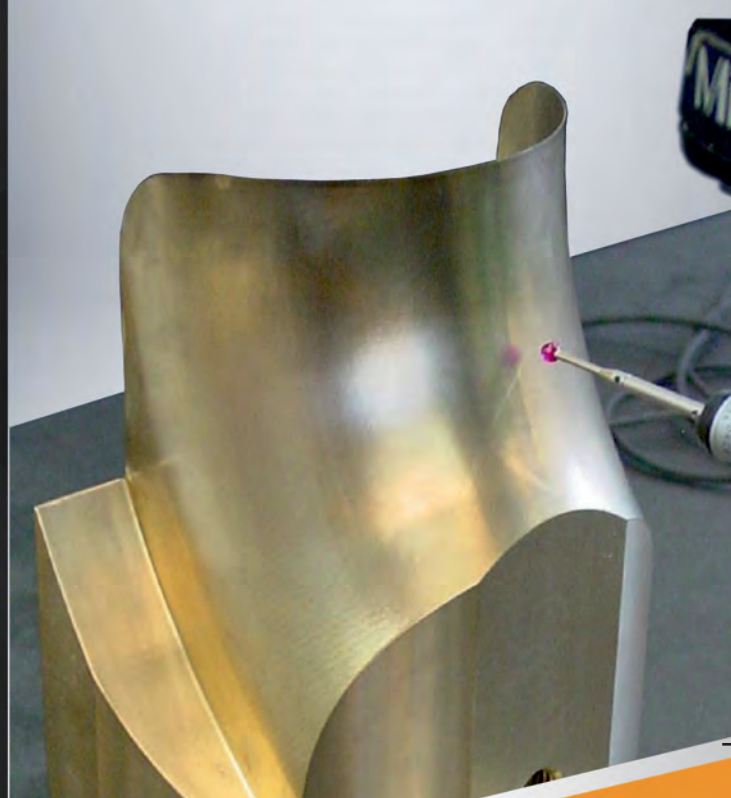

At AMPCO METAL, our expert engineers and facilities are committed to providing the best metal solution that performs exceptionally exceeding our customers' requirements and improving overall quality and productivity. This is the result of quality measurement and constant improvement of production processes.

All our tools are processed through rigorous quality control standards. We have sophisticated inspection equipment, including Coordinate Measuring Machines, to ensure that every component we produce meets the highest quality standards. This meticulous attention to detail guarantees that their customers receive nothing less than the best.

All our materials are identified at all stages of the production process and are thoroughly analyzed and checked before delivery.

All material produced can be supplied with full verification in accordance with specs, whether chemically, mechanically, or dimensionally.

BEND DIE SET

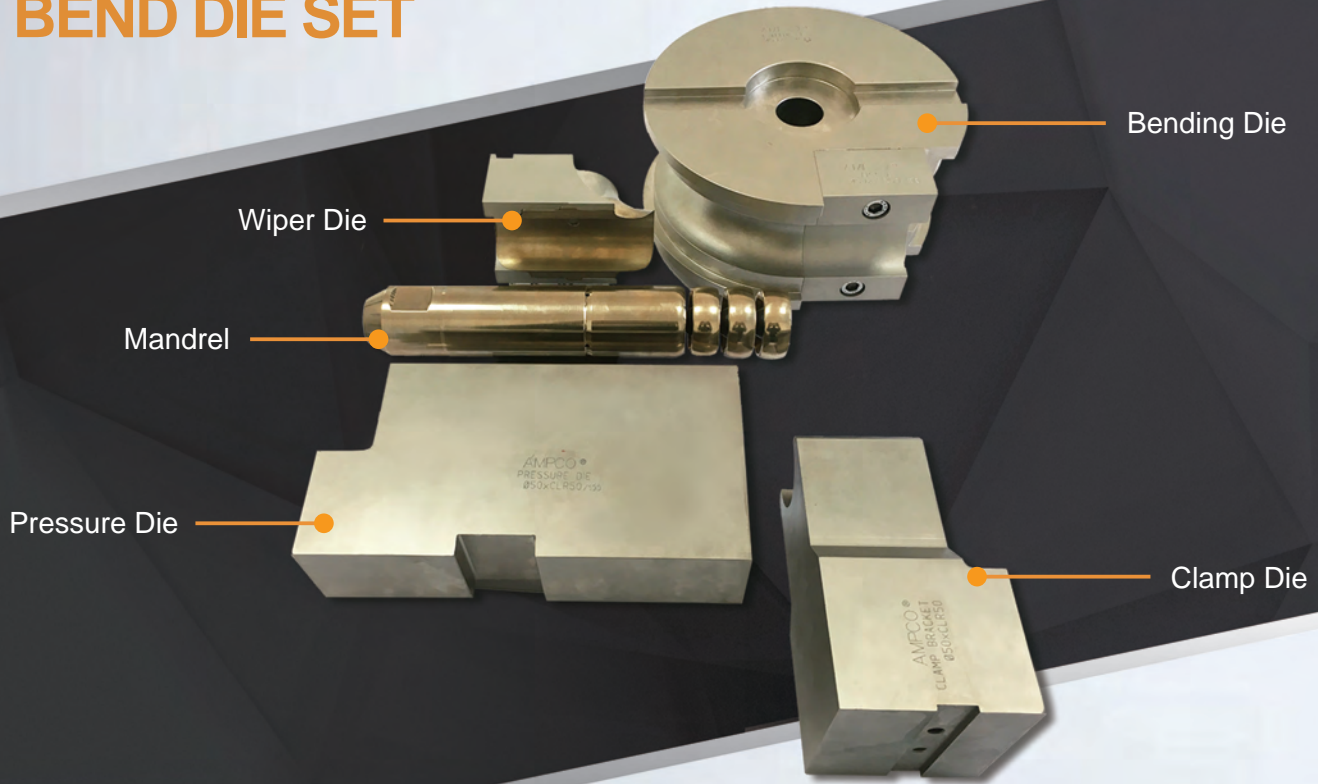

Rotary draw bending is the most popular form of tube bending used in industries like aerospace, automobile, furniture etc. Rotary draw bending can create precision bends in a repeatable process with the use of precision tooling die set.

BEND DIE

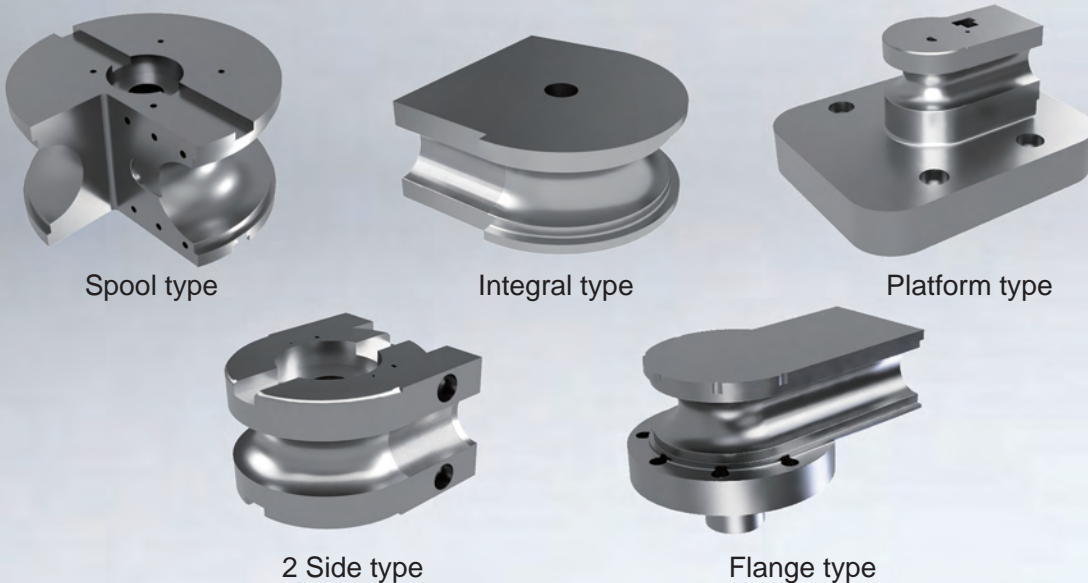

Tube bend configuration & machine mounting are the important factors for deciding which type of bend die should be used. A bending die is a tool that allows tubes to be bent around it. It defines the radius for the bend component.

CLAMP DIE

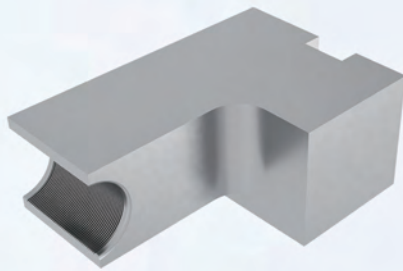

Straight clamps

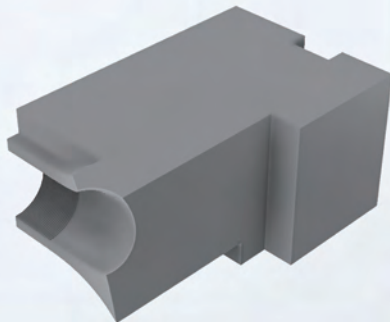
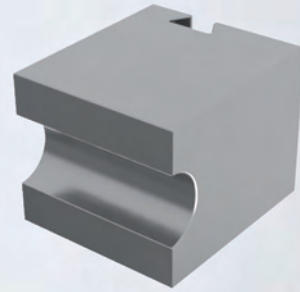

Compound clamps

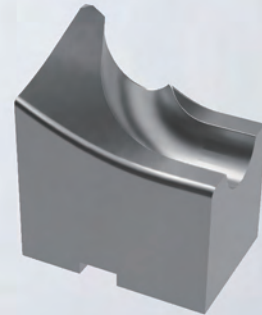

It is hardened tool steel used for holding the tube against the Bending Die under pressure applied by the bending machine throughout the bending. Tube grooves can be roughened. Cavity textures are good when distance between bends is shorter than the ideal length of the clamp die but significantly shorter than the ideal length compound cavity needed.

REVERSE INTERLOCKING

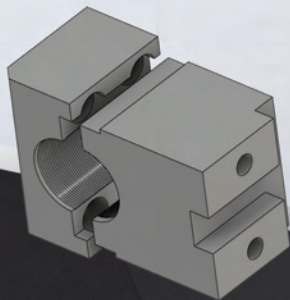

Lip lock

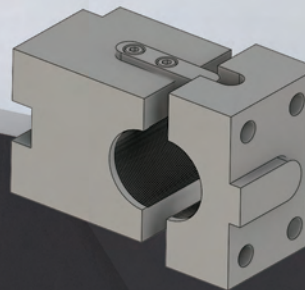

Key type

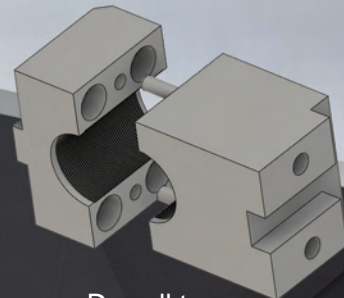

Dowell type

Smooth functioning of the tool set & producing bent tubes without any defects are results of correct alignment of the bend die with clamp die & pressure die. Our designs help the tools to self-align & maintain the alignment during operation.

PRESSURE DIE

It is hardened tool steel; the tube groove has a smooth finish to avoid drafting marks on the tube. The length of the pressure die depends on the CLR and bend angle. It holds the tube against the wiper die under pressure applied by the bending machine at the tangency line.

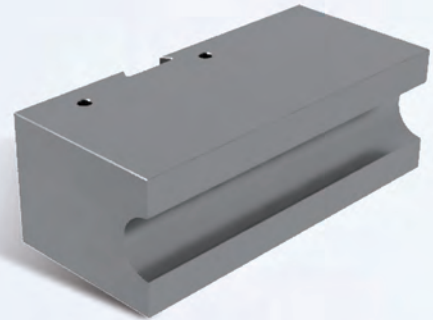

GRIPPING SOLUTIONS

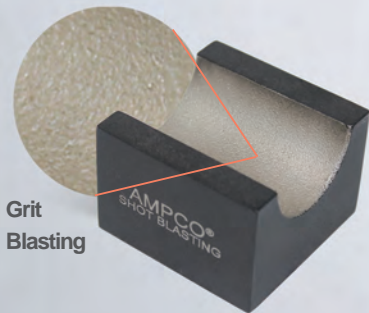

Grit
Blasting

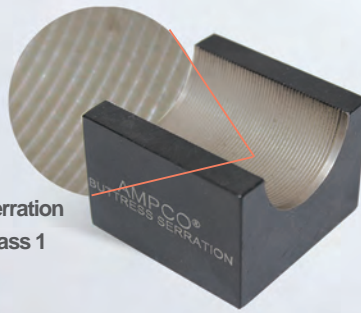

Serration
Class 1

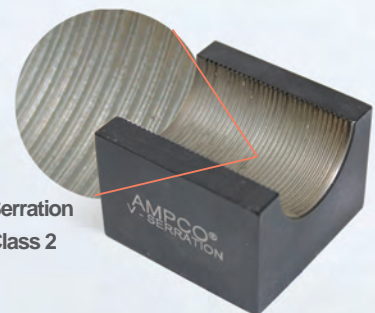

Serration
Class 2

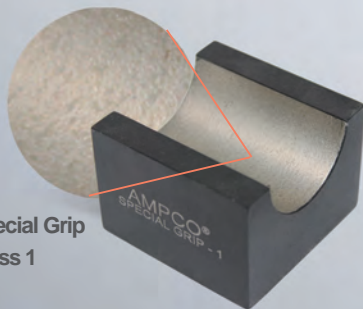

Special Grip
Class 1

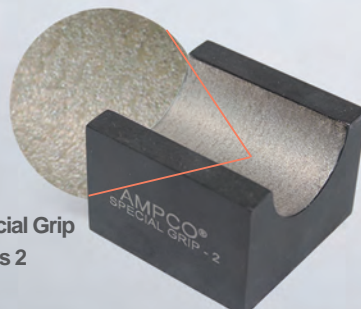

Special Grip
Class 2

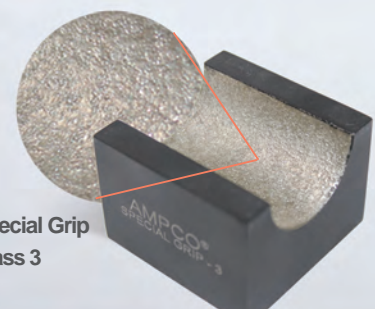

Special Grip
Class 3

Holding the tube firmly between the Bend Die & Clamp Die is fundamental in rotary draw bending. AMPCO METAL offers various gripping solutions which greatly extends the tool life. AMPCO® Gripping Solutions for tube rotary draw bending offer significant advantages:

- No tube slippage while bending
- No marks on the tube
- Solution available for short clamping length
- Suitable for compound angle too

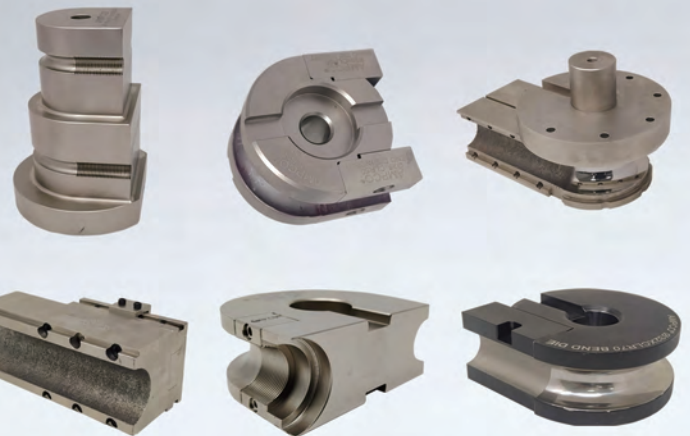

OVAL BEND TOOL SET

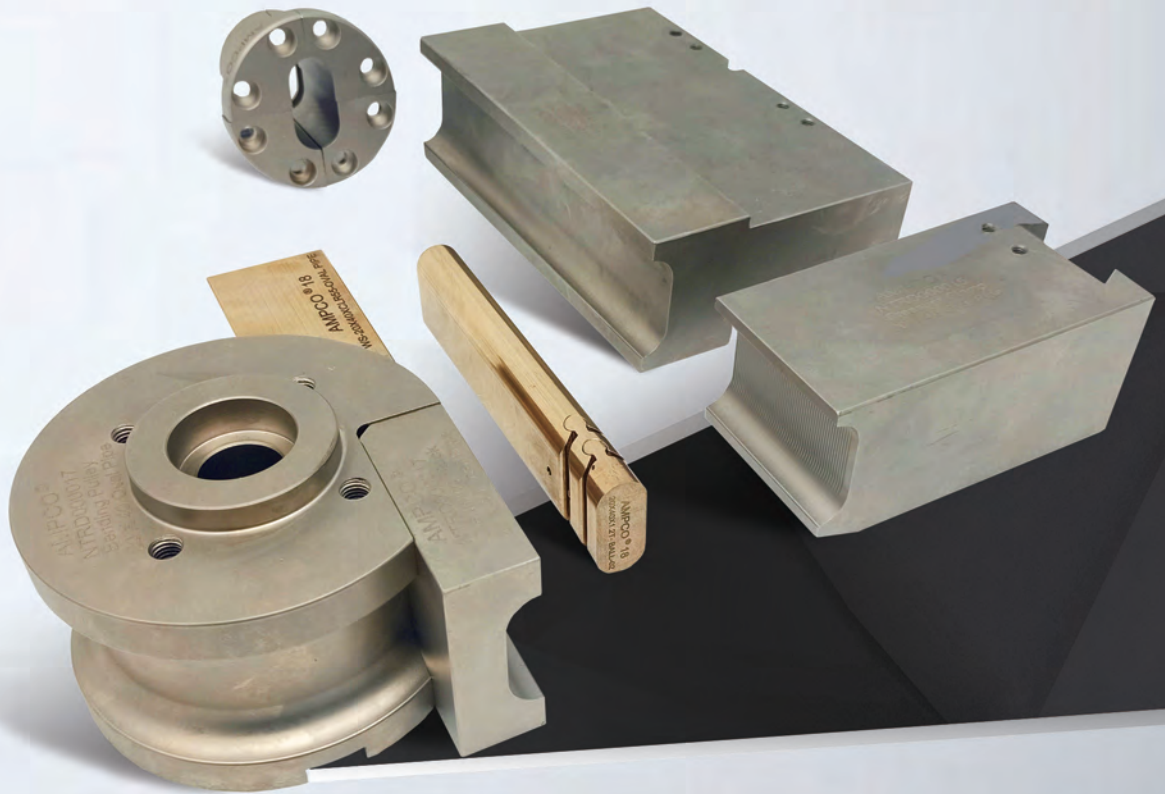

MULTI STACK BEND TOOL SET

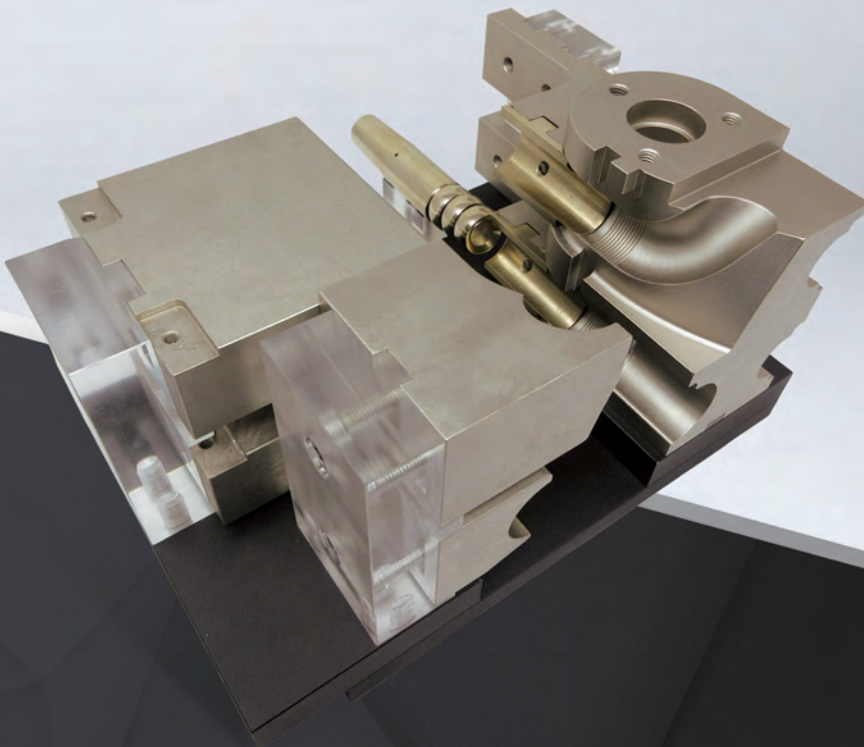

FLEXIBLE BALL MANDRELS



For tube bending of stainless steel and titanium exhaust pipes, AMPCO® 18, AMPCO® 21, and AMPCO® M4 are used with great benefits for product quality and long-life of the production tooling.

Advantages of AMPCO® 18 mandrels:

- Perfect product finish for exhaust pipes made from Aluminized steel
- Extended life of the tooling
- Cost savings due to minimal downtime for maintenance

Advantages of AMPCO® M4 Mandrels:

- Extended life, lasts up to 20 times longer
- Perfect Stainless-steel tube
- No hardening or expensive coatings required



Rectangular Mandrel - Pin Type



Square Mandrel - Link & Pin type



Oval Mandrel



Flexible Link type Ball mandrel



Ball mandrel - Link Type

WIPER DIES AND INSERTS

For tube bending of stainless steel and titanium exhaust pipes, AMPCO® 18, AMPCO® 18.23, and AMPCO® M4 are used with great benefits for product quality and the long life of the production tools.

Advantages of wiper dies made of AMPCO® alloys

- Perfect exhaust pipes of out aluminized steel
- Extended life of the tools
- Cost savings with minimal maintenance downtime
- Extended life, lasts up to 20 times longer
- Perfect finish for stainless steel tubes
- No galling, no scratching, and no corrosion starting point



END FORMING & CALIBRATION BALLS



This type of end forming tooling supports material forming from both sides to deliver tighter roundness tolerances for joining or welding.

End-forming tools are used for flaring, beading, large expansions, or reductions using multi ram tooling to gradually move the material to prevent stresses that could crack or break material.

- Provides a high-quality surface finish
- Form symmetrical and non-symmetrical shapes
- Provides better roundness
- Specifically designed for angle requirements

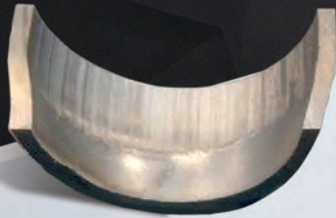

Without AMPCO®



With AMPCO®

LINKS

The whole family of link sizes has a uniform pitch length that ensures the strength and integrity of the link design which remains proportional to the tube's size.

The material is a high-quality tool steel that boasts a higher tensile and yield strength.



Product overview - Flexible mandrel

Link sizes for Flexible mandrel

Size	For TUBE Ø	Description
#2	7,95 mm to 12,5 mm	AMPCO® LINK 02
#3	12,6 mm to 15,8 mm	AMPCO® LINK 03
#4	15,9 mm to 18,9 mm	AMPCO® LINK 04
#5	19,0 mm to 23,9 mm	AMPCO® LINK 05
#6	24,0 mm to 28,4 mm	AMPCO® LINK 06
#7	28,5 mm to 37,5 mm	AMPCO® LINK 07
#8	38,0 mm to 43,5 mm	AMPCO® LINK 08
#9	44,0 mm to 53,0 mm	AMPCO® LINK 09
#10	53,5 mm to 66,0 mm	AMPCO® LINK 10
#11	66,5 mm to 85,0 mm	AMPCO® LINK 11
#12	85,5 mm to 117 mm	AMPCO® LINK 12





EXCELLENCE IN ENGINEERED ALLOYS

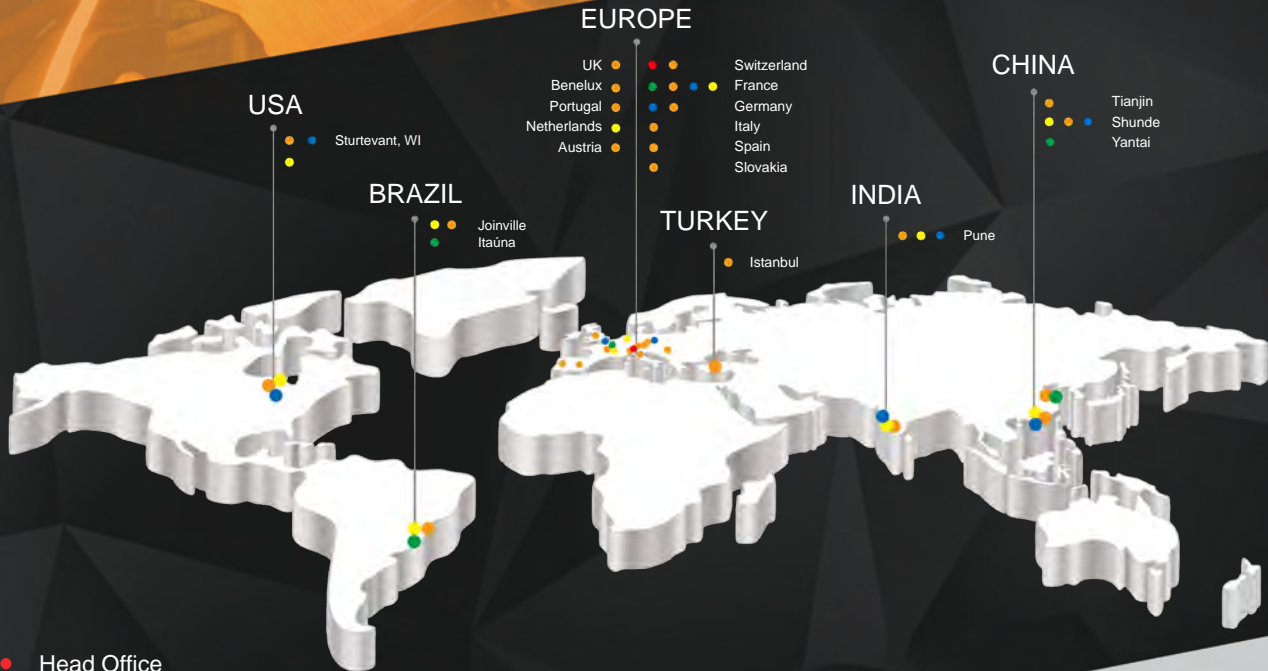

- Head Office
- Foundry
- Machining Facility
- Distribution Center
- Sales Office



EUROPE (Headquarters)

AMPCO METAL S.A.
Route de Chésalles 48
P.O.Box 45, 1723 Marly
SWITZERLAND
TOLL FREE PHONE: 800 8080 5050
Tel.: +41 26 439 93 00
Fax. +41 26 439 93 01
Info@ampcometal.com

BRASIL

AMPCO METAL Brasil Ltda.
Rua Dona Francisca 8400 - galpão 2
Zona Industrial Norte
Joinville, SC - 89219 - 600
Tel.: +55 47 3305 0020
Fax. +55 47 3305 0021
Infobrasil@ampcometal.com

CHINA

AMPCO METAL (Foshan) Co., Ltd
Warehouse 9-1 No 9 Xinyue road
Jinqiao Industrial city, Wusha
Daliang town, Shunde, Foshan
Guangdong Province, P.R.China.
P.C.528333
TOLL FREE PHONE: 4008 899 028
Tel.: +86 (0) 757 2232 6571
Fax. +86 (0) 757 2232 6570
Infochina@ampcometal.com

INDIA

AMPCO METAL INDIA PVT. LTD.
A-8/4, Village - Nighoje,
Chakan MIDC, Phase IV, Tal : Khed
Pune – 410501, Maharashtra - INDIA
Tel.: +91 2135 610 810
Fax. +91 2135 610 811
Infoindia@ampcometal.com

U.S.A

AMPCO METAL Inc.
1221 Grandview Pkwy
Sturtevant, WI 53177
Tel.: +1 800 844 6008
Fax. +1 847 437 6008
Infousa@ampcometal.com

